

Gleisauflistung TTe

Maßstab 1 : 1

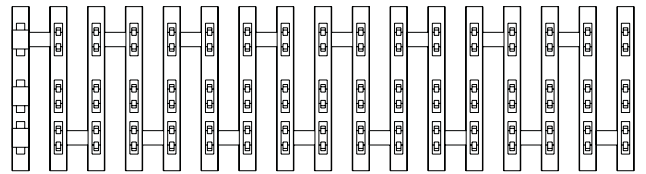
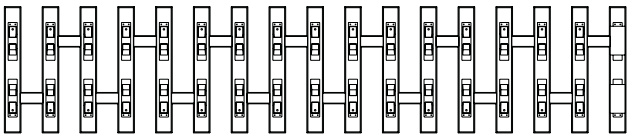

Flexgleis TTe Best.Nr. 50901
10 Roste a 80mm Profilh. 2,07mm

Flexgleis TT/TTe Best.Nr.50902
10 Roste a 80mm Profilh.2,07mm

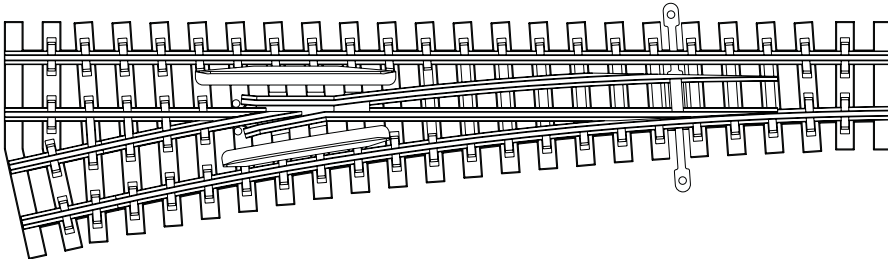

Weiche links TTe
122mm lang Profilh.
2,07mm
Bestell.Nr. 50912

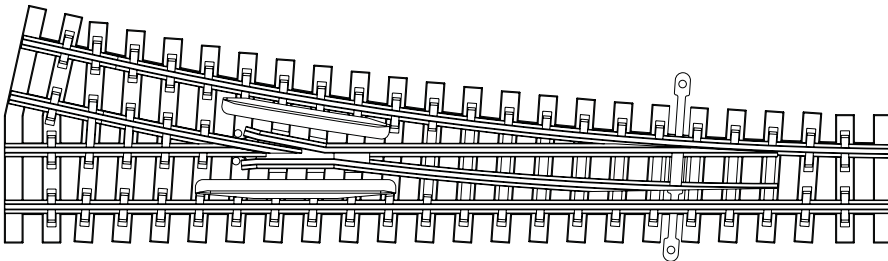

Weiche rechts TTe
122mm lang Profilh.
2,07mm
Bestell.Nr. 50911

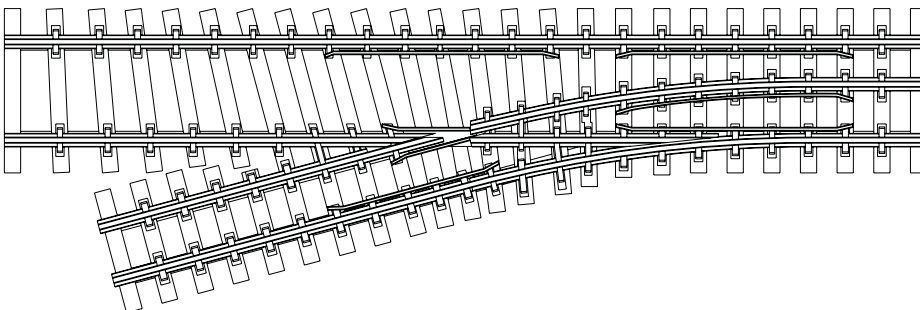

Einfädung links
TT/TTe122mm lang
Profilh. 2,07mm
Bestell.Nr. 50914

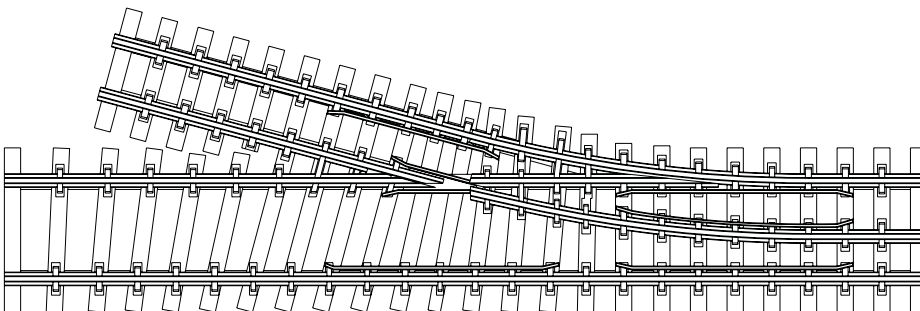

Einfädung rechts
TT/TTe122mm lang
Profilh. 2,07mm
Bestell.Nr. 50913

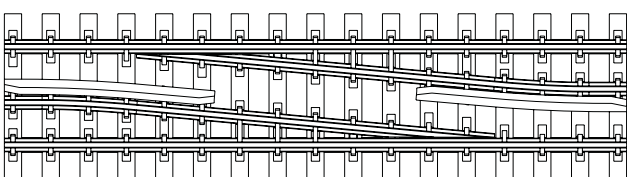

Gleiswechsel links TT/TTe
122mm lang Profilh. 2,07mm
Bestell.Nr. 50916

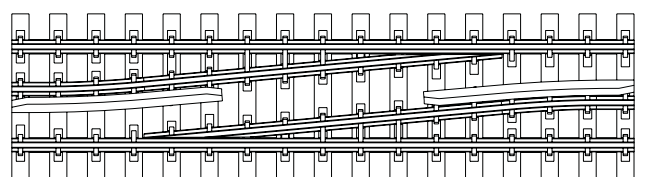

Gleiswechsel rechts TT/TTe
122mm lang Profilh. 2,07mm
Bestell.Nr. 50915

**Kreuzung rechts TT/ TTe
160mm lang Profilh.
2,07mm
Bestell.Nr. 50921**

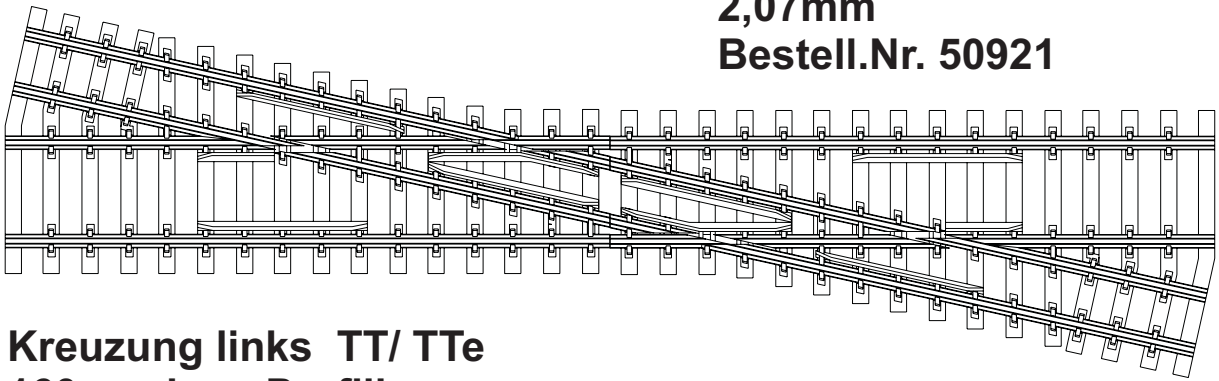

**Kreuzung links TT/ TTe
160mm lang Profilh.
2,07mm
Bestell.Nr. 50922**

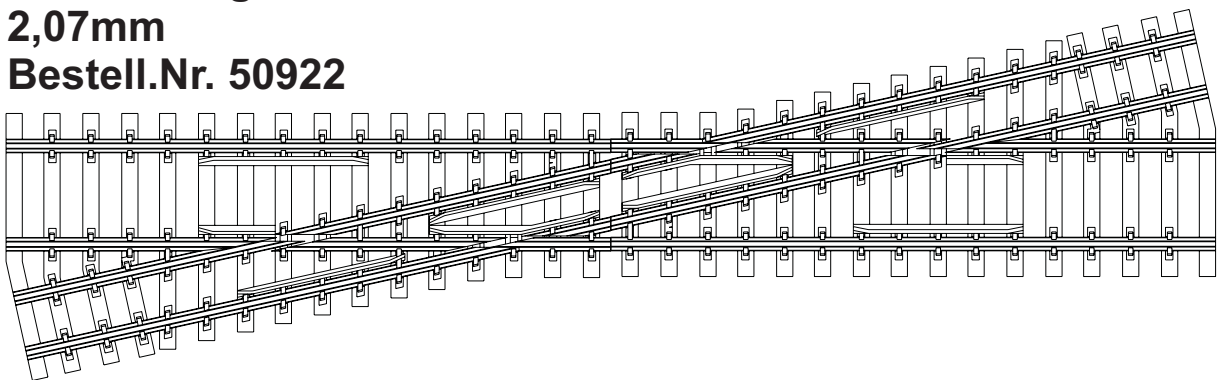

**Alle Weichen und Kreuzungen
müssen polarisiert werden**

**3 Schienen
Weiche links
TT/TTe122mm lang
Profilh. 2,07mm
Bestell.Nr. 50916**

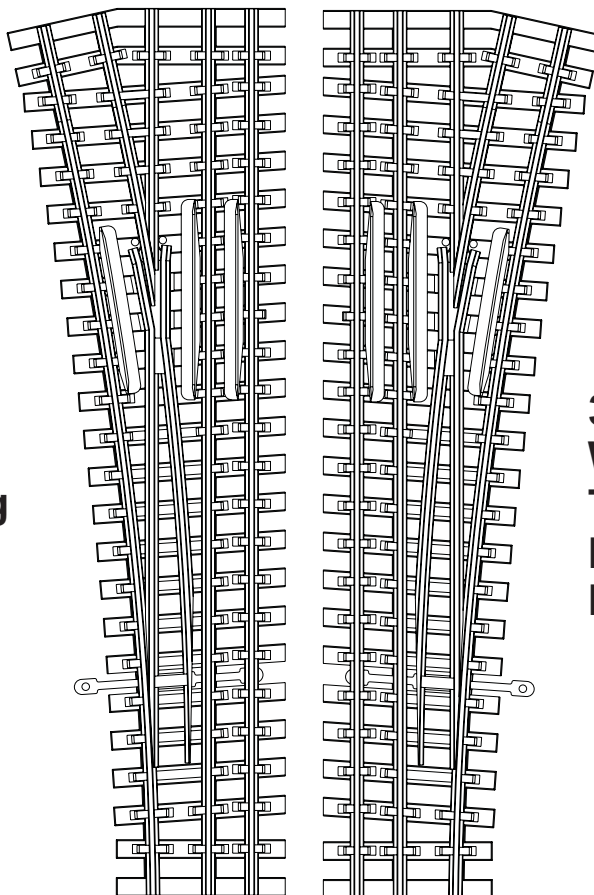

**3 Schienen
Weiche rechts
TT/TTe122mm lang
Profilh. 2,07mm
Bestell.Nr. 50916**

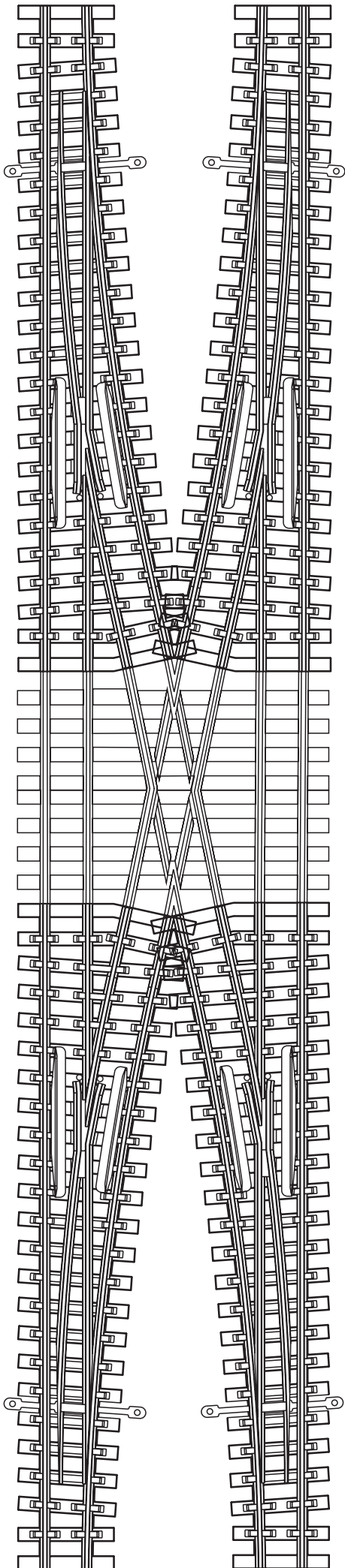

Doppelte Gleisverbindung TTe
275 mm lang Profilh.2,07mm
Gleismittenabstand 36mm
Bestell.Nr. 50928

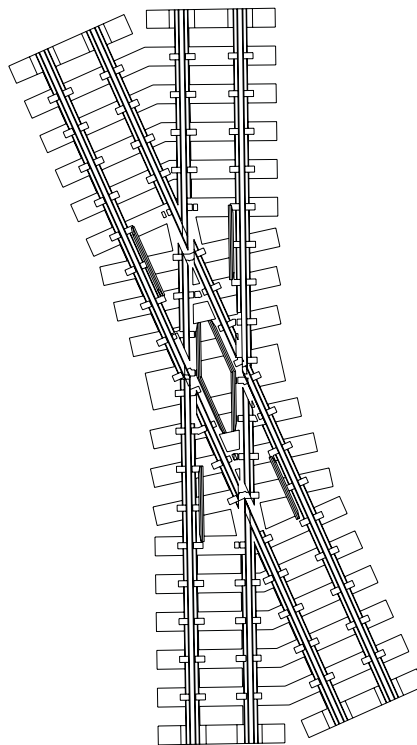

Kreuzung TTe
97,5 mm lang Profilh.2,07mm
25°
Bestell.Nr. 50927